

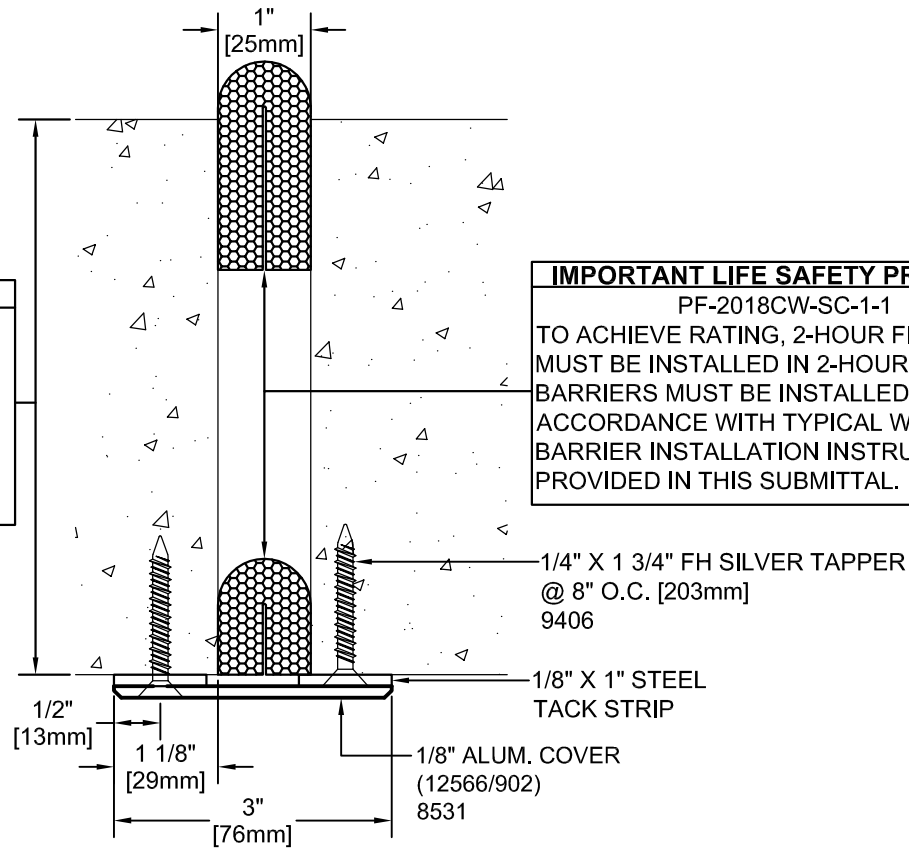

IMPORTANT LIFE SAFETY NOTE
 NOTE 2 BARRIERS REQUIRED.
 MINIMUM WALL DEPTH REQUIRED FOR RATING:
 6.125" FOR SINGLE SIDE INSTALLATION (SHOWN)
 6.125" FOR DUAL SIDE INSTALLATION
 ARCHITECT / CONTRACTOR MUST VERIFY PRIOR
 TO FABRICATION



IMPORTANT LIFE SAFETY PRODUCT NOTE
 PF-2018CW-SC-1-1
 TO ACHIEVE RATING, 2-HOUR FIRE BARRIER
 MUST BE INSTALLED IN 2-HOUR RATED WALL.
 BARRIERS MUST BE INSTALLED IN STRICT
 ACCORDANCE WITH TYPICAL WALL FIRE
 BARRIER INSTALLATION INSTRUCTIONS
 PROVIDED IN THIS SUBMITTAL.

Model	Nominal "JT"	Joint Opening "JT"				Total Movement	Mat. Code
		Seismic Min.	Thermal Min.	Thermal Max.	Seismic Max.		
SP-1-1 CONC_WPF	1"	0.875"	0.875"	1.25"	1.75"	0.875"	SM1903

Representative: _____ Customer: _____ Project: _____ Location: _____ Project Number: _____



MM SYSTEMS
 50 MM WAY
 PENDERGRASS, GA. 30567
 PHONE: 706-824-7500
 800-241-3460
 FAX: 706-824-7501
www.mmsystemscorp.com
 For Spec-Data, Installation Guides, or movement requirements, contact MMSC

RIGHTS OF DESIGN
 All rights of design, detail, engineering and/or invention contained herein are the property of MM Systems Corporation and hereby reserved and are not to be reproduced or provided to any other party. MM Systems Corporation reserves the right to amend or withdraw any information contained herein without notice and will not be liable for any inaccuracy or ambiguity of said information.

Model: SP-1-1 CONC_WPF

Drawn by: LMP	Scale: NTS	Drawing Number: SM1903
SHT. . OF .	Issue Date: 03-06-13	