

IMPORTANT LIFE SAFETY NOTE
 4-1/2" MINIMUM FACE OF SLAB (AS SHOWN) REQUIRED FOR OPTIONAL FIRE RATING TO BE AVAILABLE.
 ARCHITECT / CONTRACTOR MUST VERIFY PRIOR TO FABRICATION.

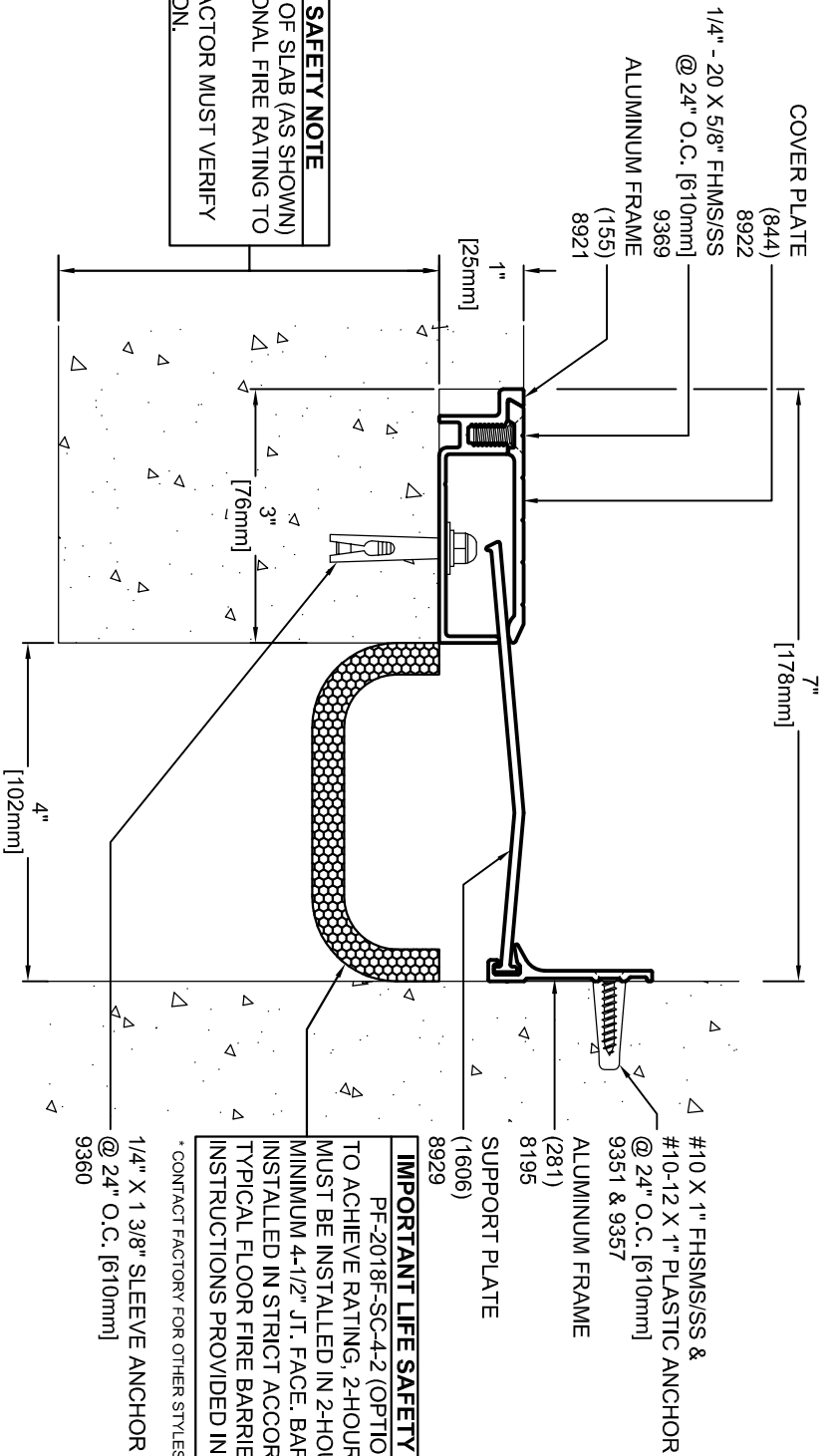

IMPORTANT LIFE SAFETY PRODUCT NOTE
 PF-2018F-SC-4-2 (OPTIONAL)
 TO ACHIEVE RATING, 2-HOUR FIRE BARRIER MUST BE INSTALLED IN 2-HOUR RATED SLAB. MINIMUM 4-1/2" JT. FACE. BARRIERS MUST BE INSTALLED IN STRICT ACCORDANCE WITH TYPICAL FLOOR FIRE BARRIER INSTALLATION INSTRUCTIONS PROVIDED IN THIS SUBMITTAL.

* CONTACT FACTORY FOR OTHER STYLES OF FIRE BARRIER

1/4" X 1 3/8" SLEEVE ANCHOR @ 24" O.C. [610mm] 9360

Model	Nominal "JT"	Joint Opening "JT"		Total Movement	Mat. Code
		Seismic Min.	Thermal Min.		
HFXE-4-1	4"	3.0"	3.0"	5.0"	CC1306
HFXE-4-1 w/ PF-2018F-SC-4-2	4"	3.0"	3.0"	5.0"	CC1306

ARCHITECT/CONTRACTOR NOTE:
 ALL SUBASSEMBLY COMPONENTS TO BE PROVIDED IN 10'-0" OR 20'-0" STOCK LENGTHS UNLESS OTHERWISE NOTED. THE SPECIFIC SYSTEMS DICTATE THE LENGTHS PROVIDED.

Representative:

Customer:

Project:

Location:

Approved by:

Project Number:

Date:

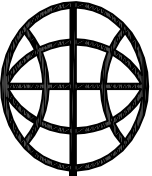

MM

MM SYSTEMS

50 MM WAY
 PENDERGRASS, GA. 30567
 PHONE: 706-824-7500
 800-241-3460
 FAX: 706-824-7501

www.mmssystemscorp.com

For Spec-Data, Installation Guides, or movement requirements, contact MMSC

RIGHTS OF DESIGN

All rights of design, detail, engineering and/or invention contained herein are the property of MM Systems Corporation and hereby reserved and are not to be reproduced or provided to any other party. MM Systems Corporation reserves the right to amend or withdraw any information contained herein without notice and will not be liable for any inaccuracy or ambiguity of said information.

HFXE-4-1

Model:
 Drawn by: MLS

SHT. OF

Scale: NTS

Issue Date: 11-12-09

Drawing Number:

CC1306